

供电模块

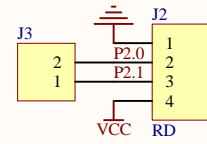

超声波模块

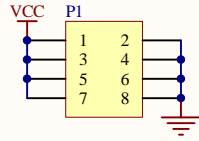

供电口

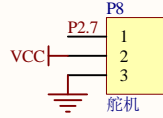

舵机模块

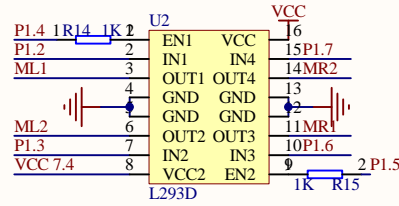

电机模块

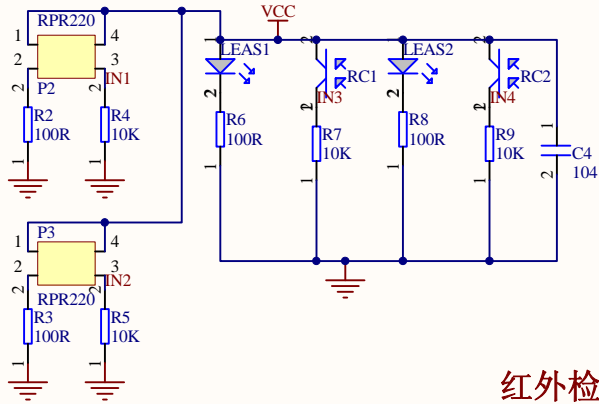
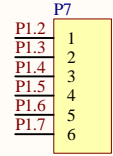
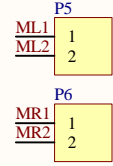

红外检测模块

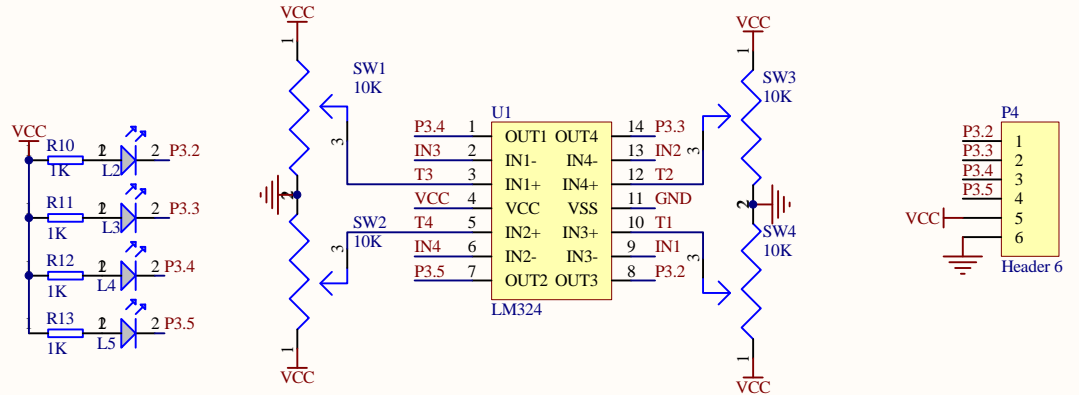

检测提示模块

亚博 BST-V51 智能小车底板电路原理图

Title		
Size	Number	Revision
A4		
Date:	2014-9-10	Sheet of
File:	D:\软件工程\智能小车\AI CAR.SchDoc	Drawn By: